

Application "FK7 DSW" Double retaining ring shaft

The double wound laminar retaining rings "FK7 DSW" for shafts are a valuable addition to the single wound laminar retaining rings "FK7 ESW".

The application range for the double wound laminar retaining rings "FK7 DSW" for shafts includes applications where the components need to be axially retained, e.g. for transmission systems, construction equipment and agriculture machinery, for fastening elements in the automotive industry and mechanical engineering, in the roller and plain bearing industry, for ship and aircraft building, winches, pulleys, etc.

Advantages of the double wound laminar retaining rings:

- Roundness of the closed winding over a range of 360° guarantees fixed contact to the groove base and full circumferential tightness
- Uniform dynamic weight during rotation
- Higher axial resilience as compared to the single wound laminar retaining rings "FK7 ESW"

Ring materials

Steel type	Spring resistant up to	Hardness	Surface protection	Surface color
C75S - DIN 1.0605	max. +300°C	on request ¹⁾	oiled	variable ²⁾
C60E - DIN 1.1221	max. +300°C	on request ¹⁾	oiled	variable ²⁾
50CrV4- DIN 1.8159	max. +400°C	on request ¹⁾	oiled	variable ²⁾
CrNi - DIN 1.4310	max. +450°C	on request ¹⁾	bright and dry	variable ²⁾

¹⁾ Variable depending on the thermal treatment type! Hardness values depending on ring cross section measured in Rockwell HRA or HRC.

²⁾ The surface color can vary depending on the thermal treatment type: bright, light brown or blackened.

Permissible circumferential speed (in m/s)

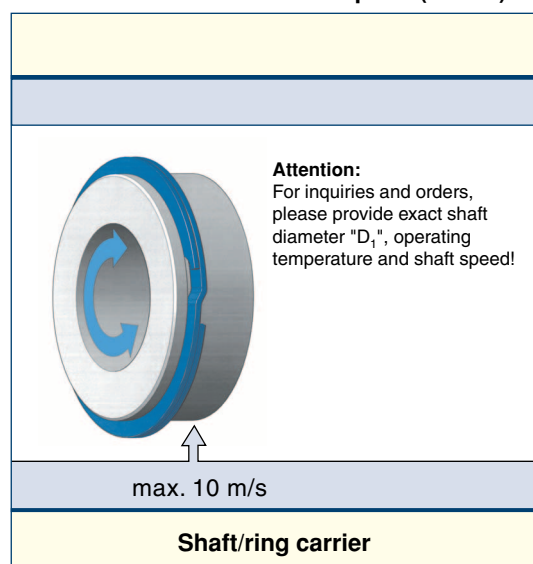

Axial stress ³⁾

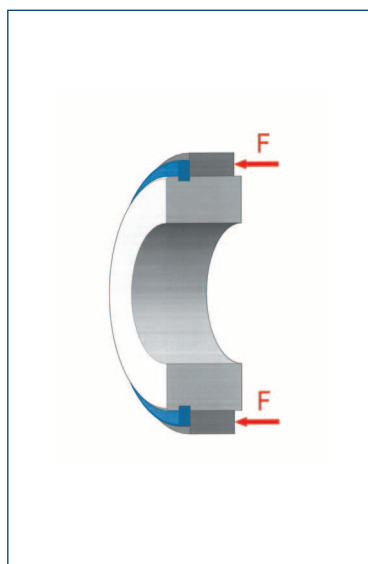

FK7 DSW ring ⁴⁾



Axial stress ³⁾:

Shearing tests under operating conditions must be performed to determine the axial shearing capacity of the retaining rings. The secure position of the retaining rings in the groove cannot be guaranteed if the surrounding components thrust uncontrollable against the laminar rings during operation (coupling effect) or if the components vibrate extremely.

Installation information:

See pages 38 and 39.

Order information ⁴⁾:

The ring diameter information must match shaft diameter dimensions "D₁" for all inquiries and/or orders.

Run and installation tests:

Run and installation tests under operating conditions must be performed in each case before standard production of our laminar rings can begin to determine whether the retaining rings can withstand the required stress.

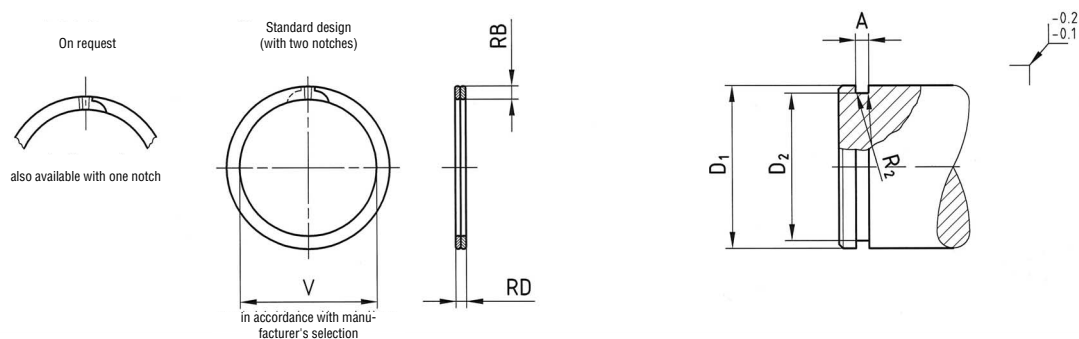

Nominal dimension		Ring dimensions				Groove dimensions										
Shaft D ₁	Tolerance	RB	Tolerance	RD	Tolerance	D ₂ = D ₁ minus	Tolerance	A	Tolerance	R ₂						
15 - 20.9 21 - 29.9	h 6 h 7	1.5 1.8	+ 0.1 - 0.2	1.3 1.3	+ 0.1 - 0.04	- 0.8 - 0.9	+ 0 - 0.1	1.45 1.45	+ 0.05 - 0	0.1						
30 - 35.9 36 - 42.9		2.2 2.8		1.45 1.65		- 1.2 - 1.6		1.6 1.8								
43 - 51.9 52 - 59.9		3.1 3.5		1.65 1.65		- 1.8 - 2.0		1.8 1.8								
60 - 69.9 70 - 74.9		3.8 4.1		1.65 1.65		- 2.0 - 2.5		1.8 1.8								
75 - 79.9 80 - 89.9		4.3 4.6		1.98 1.98		- 2.5 - 2.8		2.15 2.15								
90 - 99.9 100 - 109.9		5.0 5.5		1.98 1.98		- 3.0 - 3.0		2.15 2.15								
110 - 129.9 130 - 149.9		h 7 h 8		6.0 6.0		+0.1/-0.2 +0.15/-0.3		2.0 3.0			+0.12/-0.06 +0.15/-0.08	- 3.5 - 3.5	+ 0 - 0.2	2.2 3.2	+0.1/-0 +0.15/-0	0.2
150 - 169.9 170 - 199.9		7.0 8.0		3.0 3.0		- 4.0 - 5.0		3.2 3.2								
200 - 259.9 260 - 319.9		9.0 10.0		3.0 3.0		- 5.0 - 5.5		3.2 3.2								
320 - 399.9 400 - 439.9		h 8 h 9		11.0 12.0		3.0 3.0		- 6.0 - 7.0			3.2 3.2					
440 - 599.9 600 - 699.9	12.0 14.0	5.0 5.0	- 7.0 - 8.0	5.3 5.3												
700 - 799.9 800 - 899.9	16.0 18.0	5.0 5.0	- 9.0 - 10.0	5.3 5.3												
900 - 999.9 1000 - 1300	h 9 h 10	20.0 22.0	5.0 5.0	- 11.0 - 12.0	5.3 5.3											

FK 7

DSW

All dimensions in mm

Note: Please refer to the information on pages 2, 38, 39, 40 and 41 (questionnaire).

For inquiries and orders, please provide the exact shaft diameter "D₁", operating temperature and shaft speed!